

# Multilin EPM 9700

## High Performance Power Quality Metering with Advanced Logging and Communications

The Multilin™ EPM 9700 is a high performance power quality meter with advanced logging capabilities and flexible communication options. As a member of GE's EPM meter family, the EPM 9700 provides a comprehensive picture of power quality and consumption for metered points within an electrical system, empowering users to make power related analysis and decisions quickly and effectively, as well as recording data for accurate reconciliation.

The versatile transducer and optional display installation, along with comprehensive and innovative metering and communication features, makes the EPM 9700 ideal for utility, industrial and commercial power quality applications.

The EPM 9700 is also an enhanced, direct retrofit upgrade replacement for the EPM 9450/9650.

### Key Benefits

- Ideal for revenue and power quality monitoring with high resolution waveform recording (up to 1024 samples/cycle) and high accuracy 0.06% watt-hour energy metering with demand and time of use capture
- Improved metrology uses high and low gain sensors for high 0.06% accuracy as well as installation flexibility using both 1A and 5A secondary CTs
- Large 1.2GB logging memory makes it possible to log years of captured data
- Easy integration with standard 6 ports (4 serial/2 Ethernet) of flexible communications options and protocol support for simultaneous Modbus and DNP3 communications
- Post Installation upgradable for future requirements with modular communications external I/O and software option functionality upgrades
- Separate meter unit and optional display for flexible and easy installation
- Direct upgrade for EPM 9450/9650 with same wiring/cutout for meter unit/display installation

### Applications

- Power quality alarming/event capture for utility or industrial event investigation/reconciliation, ensuring uptime and predictive maintenance for critical power quality sensitive assets utility substation, data centers, manufacturing, hospitals
- Revenue energy billing or reconciliation (demand, time of use) and for utility or industrial applications
- High speed data capture and control in applications such as generation or renewables
- Specialized utility/industrial power quality reporting for Class A IEC 61000-4-30 Ed. 3, IEC 61000-4-15 Flicker, IEC 61000-4-7 Harmonics and EN50160 standards



## Advanced Monitoring and Metering

- 0.06% Energy Accuracy (ANSI 0.2% Accuracy Class)
- Harmonics to the 511th order voltage, current, 127th order in real time
- Up to 1024 samples/cycle based measurements
- Up to 1.2 GB of logging memory with default preconfigured logging of 142 essential parameters
- Updated IEC 61000-4-30 Class A Edition 3 Power Quality Measurement and EN50160 Reporting Support

## Advanced Communications and Control

- 6 standard communications ports supporting serial (RS232, RS485); Ethernet (RJ45, ST Fiber Optic independent ports, unique IP)
- Support for Modbus, DNP 3.0 protocols
- Easy system integration with standard pulse outputs and digital inputs as well as expandable external analog, digital and relay outputs

## User Friendly with Low Commissioning Effort

- Advanced Web Server for data visualization and waveform Analysis
- Automated logging architecture to capture default logging values
- Separate meter unit and optional 3 line P40NPLUS LED display for easy and cost effective installation
- Direct retrofit upgrade for EPM 9450/9650

## Advanced Metering, Logging and Communications for Utility or Industrial Applications

The EPM 9700 provides high performance power quality analysis functions collecting data to support the reporting of the latest IEC 61000-4-30 Class A Edition 3 and EN50160 international standards and providing a deep perspective when investigating sources of faults, sags and swells, and harmonics to ensure asset uptime, monitor energy usage and power quality.

Essential power quality data and events are also captured, stored and time synced, allowing for complete post-fault analysis of events. With 6 communications ports and support for Modbus and DNP3 protocols, the EPM 9700 is easy to integrate into a SCADA or data analysis system. The EPM 9700 HTML 5 web server also provides remote, simplified, secure access to data. The EPM 9700 meter base and optional P40NPLUS display allow for easy and flexible installation options, making it a clear choice for critical revenue accurate metering for power utility or industrial applications.

## Accurate Revenue Energy Metering

The EPM 9700 uses advanced high and low gain current sensors for each of the current inputs and determines the optimal sensing circuit for the highest accuracy measurement. This allows the EPM 9700 to have 0.06% accuracy (ANSI Class 0.2%) in an extended measurement range. The wide range pickup of the meter current sensors used also allow the same meter to be used for both 5A and 1A secondary CTs which allows for easier ordering and standardization for multiple applications.

## Comprehensive, Upgradable Features

A multitude of basic features are standard in the EPM 9700. The software options are also upgradeable in field after installation through an unlock key in the software setup, providing more functionality with the same installed unit in the future. The following table illustrates the available features and upgrades.

## Direct Retrofit Upgrade for EPM 9450/9650

The EPM 9700 is a direct retrofit upgrade for existing EPM 9450/9650 installations, saving on hardware and installation costs while providing a comprehensive set of new features.

- Direct meter unit wiring replacement (CTs, VTs, comms, I/O, power supply)
- Reuse existing installations of EPM 9450/9650 I/O and P40NPLUS displays
- Minimal system changes to integrate new features

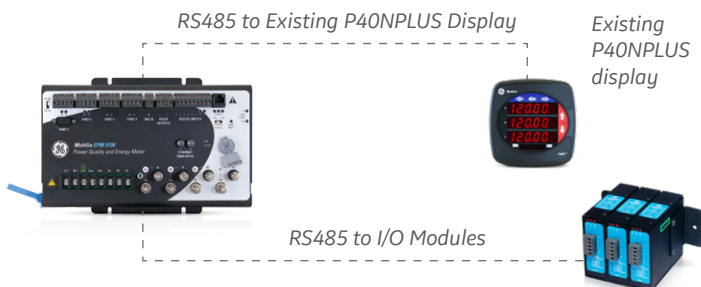

Easy direct retrofit for EPM 9450/9650 utilizing existing I/O and P40NPLUS display



MEASUREMENT	
Voltage L-N	0.04% of reading
Voltage L-L	0.04% of reading
Current	0.04% of reading
Neutral Current	0.1%
Frequency	0.004 Hz
Watts	0.06% of reading
Watt-hour*	0.06% of reading
VAR	0.15% of reading
VARh	0.15% of reading
VA	0.06% of reading
Power Factor	0.15% of reading
THD	2.5% of reading

\* (0.025 A to 20 A at PF=1): Full accuracy specifications are provided in the EPM 9700 Installation and Operation Manual.

EPM 9700 FEATURES	SOFTWARE OPTION A (BASIC)	SOFTWARE OPTION B (ADVANCED)
<b>BASIC MEASUREMENTS</b>		
Voltage, Current, etc	•	•
THD and Harmonics	•	•
Time of Use	•	•
<b>POWER QUALITY MEASUREMENTS</b>		
Waveform Recording	•	•
Sampling Rate	512	1024
Flicker	•	•
IEC 61000-4-30 Class A	S	A
EN 50160 Reporting	•	•
<b>STORAGE</b>		
CORE™ Log	•	•
Custom Historical Logs	•	•
PQ Log	•	•
Waveform Log	•	•
Limit Log	•	•
I/O Log	•	•
Memory for logging	512 MB*	1200 MB*
<b>COMMUNICATION</b>		
Serial	•	•
Modbus over Serial	•	•
DNP 3.0 over Serial	•	•
RJ45 Ethernet	•	•
Fiber Ethernet	•	•
Modbus over Ethernet	•	•
DNP 3.0 over Ethernet	•	•

\* The unit has 4000 MB flash memory installed, for longer reliable life. Some of the memory is allocated to wear-leveling and system use.

## Actionable Power Quality Insight

Accurate, high resolution and comprehensive power quality information is essential in resolving and mitigating both post-fault potential future system challenges, as well as protecting valuable assets and processes in utility and industrial applications. The EPM 9700 captures and stores comprehensive power quality information including harmonics, sags, swells and transients, providing clear evidence and a log of faults and disturbances to allow for detailed and extensive forensic engineering analysis. The EPM 9700 also has the ability to set up multiple programmable limits and notifications to ease operator monitoring.

### IEC 61000-4-30 Class A Edition 3 Power Quality Meter

- Designed specifically to meet rigorous updated IEC 61000-4-30 Class A Edition 3 standard, the EPM 9700 measures and analyzes power quality metrics precisely
- Reporting available via auto generated EN50160 weekly reporting format

### IEC 61000-4-15 Class A Flicker Meter

- Flicker measurements compliant with the IEC 61000-4-15 Class A standard
- Operates on both 220 volt/50 Hz and 120 volt/60 Hz

### IEC 61000-4-7 Class A Harmonic and Interharmonic Analysis

- View harmonic magnitudes to the 511th order for each voltage and current channel
- Harmonic magnitudes and phase angles in real time are resolved to the 127<sup>th</sup> order
- Obtain %THD, TDD, and K-Factor
- Conduct power quality analysis at the high end of the harmonic magnitude spectrum

### Limits/Alarms for Easy Operator Monitoring

- User programmable setpoints for measured values as well as Boolean logic tree for conditional actions
- Event recording based on threshold settings
- Timers and logic to trigger control events or to send email notifications

### Waveform Recording

To troubleshoot, remedy and predictively analyze potential system challenges, the EPM 9700 can record waveforms at a sampling rate up to 1024 samples/cycle on multiple power quality events, such as surges and/or sags. The 16-bit A/D conversion provides precise waveform resolution. Both voltage and current recording offer pre and post-event analysis. Fault recording offers 8 times full-scale capture capability. Both hardware and software triggers are available. GE's Communicator setup software and the EPM 9700 web server provide easy remote setup as well as visualization of waveform data.

### Phasor Analysis

GE's Communicator software also presents easily understandable phasor data, including phase angles and symmetrical components for voltage and current. This especially useful when analyzing electrical wiring and system problems during commissioning and startup.



Record and Analyze Waveform fault and Transient Data

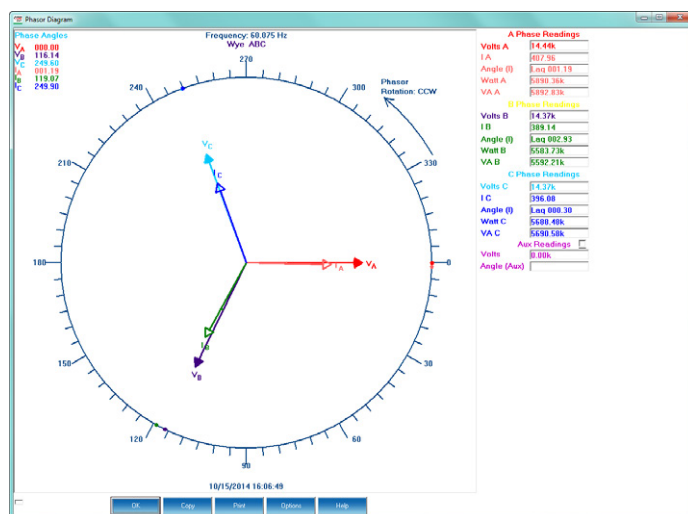

Visualize voltage/current phase angles to ensure correct setup

## Comprehensive Automated Data Logging

The EPM 9700 provides the following logging capability:

- Trending Log: The meter supports up to 8 historical trending logs of 64 data channels per log, acting as a traditional load profile recorder with up to 8 separate logs.
- System Events Security Log: This comprehensive system anti-tampering log records all system events in the meter along with an associated timestamp.

The EPM 9700 logs important system events such as:

- Resets
- Programming changes
- Password access changes
- Time changes
- Power up/down
- Change of Firmware
- Control Output Log: This log provides a time-stamped record of relay output changes.
- Input Status Change Log: This log supplies information on the state of the meter's eight high-speed inputs.
- Limit Log: The Limit/Alarm log can be set to record on high and low conditions for up to 32 user programmable limits.
- Power Quality Log: This log captures power quality events, such as surges and sags, and lets you view and analyze the data through power quality graphs, such as the ITI CBEMA Curve standard.
- The EPM 9700 meter provides advanced data logging capabilities over time, for trending and analysis. The meter has up to 1.2 GB allocated to logging and user storage, and is also preconfigured to automatically store 142 different measurements (in the CORE™ log) every 15 minutes, without any user intervention. Additionally, a user is able to configure up to 8 historical logs. All logs work with a FIFO buffer and roll over when filled.

LOG TYPE	V1 RECORD SIZE	DAYS	V2 RECORD SIZE	DAYS
System Events	16384		32768	
CORE™ Log*	16384	163	32768	327
Log 1**	16384	163	32768	327
Log 2**	16384	163	32768	327
Log 3**	16384	163	32768	327
Log 4**	16384	163	32768	327
Log 5**	16384	163	32768	327
Log 6**	16384	163	32768	327
Log 7**	16384	163	32768	327
Log 8**	16384	163	32768	327
Digital Input	16384		32768	
Limits/Alarms	16384		32768	
Relay Outputs	16384		32768	
Power Quality	16384		32768	
Waveforms***	For 512 samples per cycle, 1 second waveform recording at 60 Hz: 682 records.		For 1024 samples per cycle, 1 second waveform recording at 60 Hz: 341 records.	

\* The CORE™ log automatically records readings for 142 parameters at the logging interval. The default interval is 15 minutes. Days are based on approximately 100 records per day.

\*\* Logs 1 - 8 are user-assignable and allow 64 parameters per log. Days are based on approximately 100 records per day.

\*\*\* The number of waveform records depends on the sampling rate and the length of waveform recording. Software Option A offers up to 512 samples/cycle recording and Software Option B offers up to 1024 samples/cycle recording.

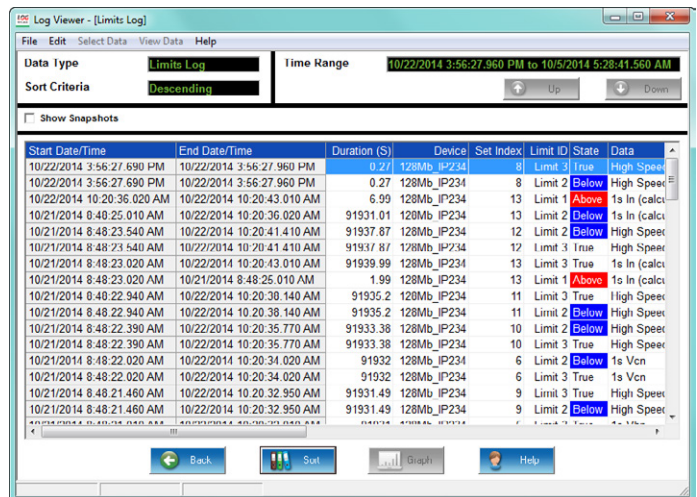

Limit log viewer

## Extensive Communications and I/O

The EPM 9700 meter is equipped with extensive communication capabilities that allow it to speak with many different SCADA or other communication systems, simultaneously. The meter has 6 communication ports as a standard offering. These ports include 4 serial ports and 2 Ethernet-based communication ports. The Ethernet ports include an ST terminated fiber optic port and an RJ45 port. Both ports use separate IP addresses, so that they can run on simultaneous redundant networks.

### Details of Ports

- 6 standard Com ports
- 4 serial ports - RS485 (one of the ports is RS485/RS232 selectable)
- 2 independent Ethernet ports - RJ45 and Fiber Optic
- Modbus RTU, Modbus ASCII, Modbus TCP/IP, DNP 3.0 Level 2 communication
- All ports can be communicating simultaneously
- Each Ethernet port can be assigned a separate IP address

### 8 Built-in Digital High-speed Status Inputs

- Inputs automatically sense whether the circuit is externally wetted
- If externally wetted, input up to 150 VDC is accepted
- If internally wetted, the meter supplies the necessary voltage for the control application

### VAUX Input

- Neutral to ground or aux voltage readings
- Synchronizing schemes, for example, obtaining the frequency, magnitude, and phase angle on both sides of a switch or between generator and bus voltage

### Two Standard Pulse Outputs

- Solid State, form-A, 35 ohm max on resistance
- 120 mA continuous, 350 mA max for 10 ms
- Peak voltage: 350 V DC
- Switching rate max: 10/s
- Support pulse-counting applications

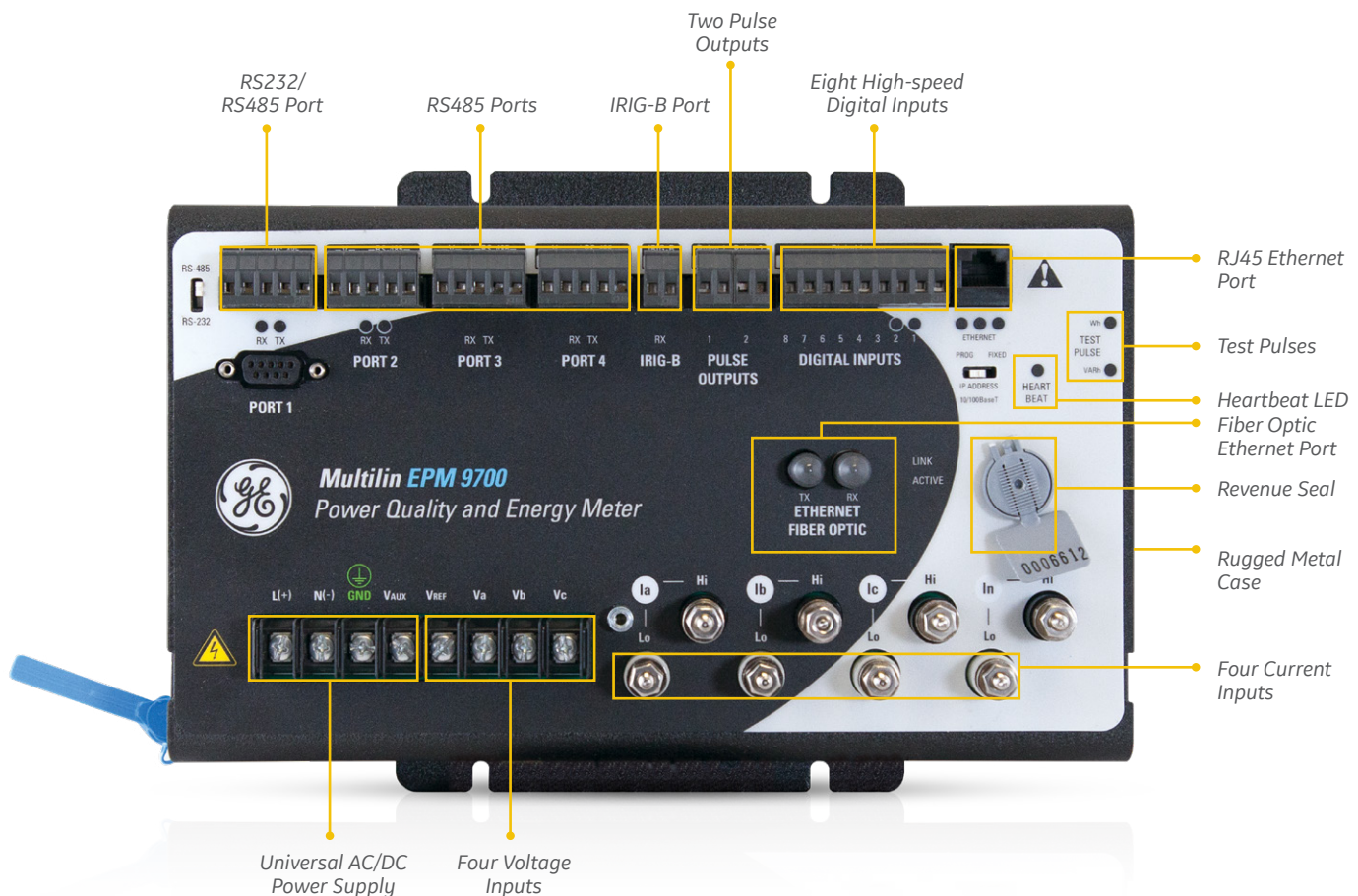

The EPM 9700 is a direct physical retrofit to EPM 9450/9650 Meters

## Optional Display and Expandable I/O Modules

### Optional Retrofit Capable Display

- Optional LED Master display, P40NPLUS supplies visual of meter readings
- Display connects to a standard RS485 port
- P40NPLUS offers USB connection to a PC for direct download of readings
- Existing P40NPLUS displays can be used for new EPM 9700 installations

### Analog Outputs

- PL90001MAON4000/PL90001MAON8000: 4 or 8 Analog Outputs, 0-1 mA, self-powered, scalable, bidirectional
- PL90002OMAON400/PL90002OMAON800: 4 or 8 Analog Outputs, 4-20 mA, self-powered, scalable
- Wiring: Common Mode
- Accuracy: 0.1% of Full Scale
- Calibration: Self-calibrating
- Scaling: Programmable
- Ordering: Up to 4 Analog Output modules

### Analog Inputs

- PL90008AI100000: 8 Analog Inputs, 0±1 mA
- PL90008AI200000: 8 Analog Inputs, 4-20 mA
- PL90008AI300000: 8 Analog Inputs, 0±5 VDC
- PL90008AI400000: 8 Analog Inputs, 0±10 VDC
- Wiring: Common Mode
- Accuracy: 0.25% of Full Scale
- Scaling: Programmable
- Ordering: Up to 4 Analog Input modules

### Digital Dry Contact Relay Outputs

- PL90004RO100000: 4 Relay Outputs, 5A, 250VAC/30 VDC, Form C Latching
- Ordering: 1 module in addition to internal modules

### Digital Solid State Pulse Outputs

- PL90004PO100000: 4 Solid State Pulse Outputs, Form A or C KYZ pulses
- Maximum Pulse Speed: 20 pulses per second
- Ordering: Up to 4 Digital Solid State Output modules

### I/O Module Accessories (Required)

- PL9000PSIO00000: Power supply required for 3 or more I/O modules or displays. Provides power for up to 4 external I/O modules or displays
- PL9000MBIO00000: Mounting bracket for external I/O modules. Must be ordered with external I/O module



## Enhanced Cyber Security

The EPM 9700 provides the latest in cyber security enhancements to the GE EPM meter product line to prevent unauthorized access and tampering. Cyber Security enhancements include:

- Highly Secure Encrypted Passwords
- 10 User IDs and Passwords - Up to 30 Characters
- Password Fail Timeouts Eliminate Brute Force Hacking
- 4 Roles with Customized User Access
- Logging of All Password and Login Attempt History
- Physical Seals and Lock-outs to Prevent Hacking or Tampering

The security enhancements are configured easily through the use of GE's Communicator setup software for EPM Meters.

## Tamper Evident Locking and Revenue Sealing

The EPM 9700 meter is lockable and sealable to provide evidence of tampering as per customer and certain utility/industry requirements.

- Two standard physical meter seals (Demand, Programming Reset Button)
- Lockable cover for voltage and current inputs
- Case seals (other than Demand/programming) are sold separately

The screenshot shows the 'Roles Overview' configuration screen. On the left, a tree view shows 'Configure Users' (Admin, Legacy, User 1-10) and 'Configure Roles' (Role 1-4). The 'Roles Overview' table lists permissions for each role and user.

Permission	Role 1	Role 2	Role 3	Role 4	Admin	User 1	User 2
<input type="checkbox"/> Reset Permissions	<input type="checkbox"/>	<input type="checkbox"/>	<input type="checkbox"/>	<input type="checkbox"/>	<input checked="" type="checkbox"/>	<input type="checkbox"/>	<input type="checkbox"/>
<input type="checkbox"/> Reset TOU Demand	<input type="checkbox"/>	<input type="checkbox"/>	<input type="checkbox"/>	<input type="checkbox"/>	<input checked="" type="checkbox"/>	<input type="checkbox"/>	<input type="checkbox"/>
<input type="checkbox"/> Reset TOU Data	<input type="checkbox"/>	<input type="checkbox"/>	<input type="checkbox"/>	<input type="checkbox"/>	<input checked="" type="checkbox"/>	<input type="checkbox"/>	<input type="checkbox"/>
<input type="checkbox"/> Reset System Event Log	<input type="checkbox"/>	<input type="checkbox"/>	<input type="checkbox"/>	<input type="checkbox"/>	<input checked="" type="checkbox"/>	<input type="checkbox"/>	<input type="checkbox"/>
<input type="checkbox"/> Reset Digital Output Log	<input type="checkbox"/>	<input type="checkbox"/>	<input type="checkbox"/>	<input type="checkbox"/>	<input checked="" type="checkbox"/>	<input type="checkbox"/>	<input type="checkbox"/>
<input type="checkbox"/> Reset Limits Log	<input type="checkbox"/>	<input type="checkbox"/>	<input type="checkbox"/>	<input type="checkbox"/>	<input checked="" type="checkbox"/>	<input type="checkbox"/>	<input type="checkbox"/>
<input type="checkbox"/> Reset Power Quality Logs	<input type="checkbox"/>	<input type="checkbox"/>	<input type="checkbox"/>	<input type="checkbox"/>	<input checked="" type="checkbox"/>	<input type="checkbox"/>	<input type="checkbox"/>
<input type="checkbox"/> Reset Historical Logs	<input type="checkbox"/>	<input type="checkbox"/>	<input type="checkbox"/>	<input type="checkbox"/>	<input checked="" type="checkbox"/>	<input type="checkbox"/>	<input type="checkbox"/>
<input type="checkbox"/> Reset Historical Core Log	<input type="checkbox"/>	<input type="checkbox"/>	<input type="checkbox"/>	<input type="checkbox"/>	<input checked="" type="checkbox"/>	<input type="checkbox"/>	<input type="checkbox"/>
<input type="checkbox"/> Reset EN50160 Log	<input type="checkbox"/>	<input type="checkbox"/>	<input type="checkbox"/>	<input type="checkbox"/>	<input checked="" type="checkbox"/>	<input type="checkbox"/>	<input type="checkbox"/>
<input type="checkbox"/> Reset Inputs and Accumulators	<input type="checkbox"/>	<input type="checkbox"/>	<input type="checkbox"/>	<input type="checkbox"/>	<input checked="" type="checkbox"/>	<input type="checkbox"/>	<input type="checkbox"/>
<input type="checkbox"/> Reset Demand	<input type="checkbox"/>	<input type="checkbox"/>	<input type="checkbox"/>	<input type="checkbox"/>	<input checked="" type="checkbox"/>	<input type="checkbox"/>	<input type="checkbox"/>
<input type="checkbox"/> Reset KYZ	<input type="checkbox"/>	<input type="checkbox"/>	<input type="checkbox"/>	<input type="checkbox"/>	<input checked="" type="checkbox"/>	<input type="checkbox"/>	<input type="checkbox"/>
<input type="checkbox"/> Reset Energy	<input type="checkbox"/>	<input type="checkbox"/>	<input type="checkbox"/>	<input type="checkbox"/>	<input checked="" type="checkbox"/>	<input type="checkbox"/>	<input type="checkbox"/>
<input type="checkbox"/> Reset Flicker Max/Min	<input type="checkbox"/>	<input type="checkbox"/>	<input type="checkbox"/>	<input type="checkbox"/>	<input checked="" type="checkbox"/>	<input type="checkbox"/>	<input type="checkbox"/>
<input type="checkbox"/> Reset Max/Min	<input type="checkbox"/>	<input type="checkbox"/>	<input type="checkbox"/>	<input type="checkbox"/>	<input checked="" type="checkbox"/>	<input type="checkbox"/>	<input type="checkbox"/>
<input type="checkbox"/> Read Permissions	<input type="checkbox"/>	<input type="checkbox"/>	<input type="checkbox"/>	<input type="checkbox"/>	<input checked="" type="checkbox"/>	<input type="checkbox"/>	<input type="checkbox"/>
<input type="checkbox"/> Read Power Quality Logs	<input type="checkbox"/>	<input type="checkbox"/>	<input type="checkbox"/>	<input type="checkbox"/>	<input checked="" type="checkbox"/>	<input type="checkbox"/>	<input type="checkbox"/>
<input type="checkbox"/> Read Historical Logs	<input type="checkbox"/>	<input type="checkbox"/>	<input type="checkbox"/>	<input type="checkbox"/>	<input checked="" type="checkbox"/>	<input type="checkbox"/>	<input type="checkbox"/>
<input type="checkbox"/> Read TOU Data	<input type="checkbox"/>	<input type="checkbox"/>	<input type="checkbox"/>	<input type="checkbox"/>	<input checked="" type="checkbox"/>	<input type="checkbox"/>	<input type="checkbox"/>
<input type="checkbox"/> Meter Actions	<input type="checkbox"/>	<input type="checkbox"/>	<input type="checkbox"/>	<input type="checkbox"/>	<input checked="" type="checkbox"/>	<input type="checkbox"/>	<input type="checkbox"/>
<input type="checkbox"/> Restart Meter	<input type="checkbox"/>	<input type="checkbox"/>	<input type="checkbox"/>	<input type="checkbox"/>	<input checked="" type="checkbox"/>	<input type="checkbox"/>	<input type="checkbox"/>

Configure User Roles and Permissions in GE Communicator Software

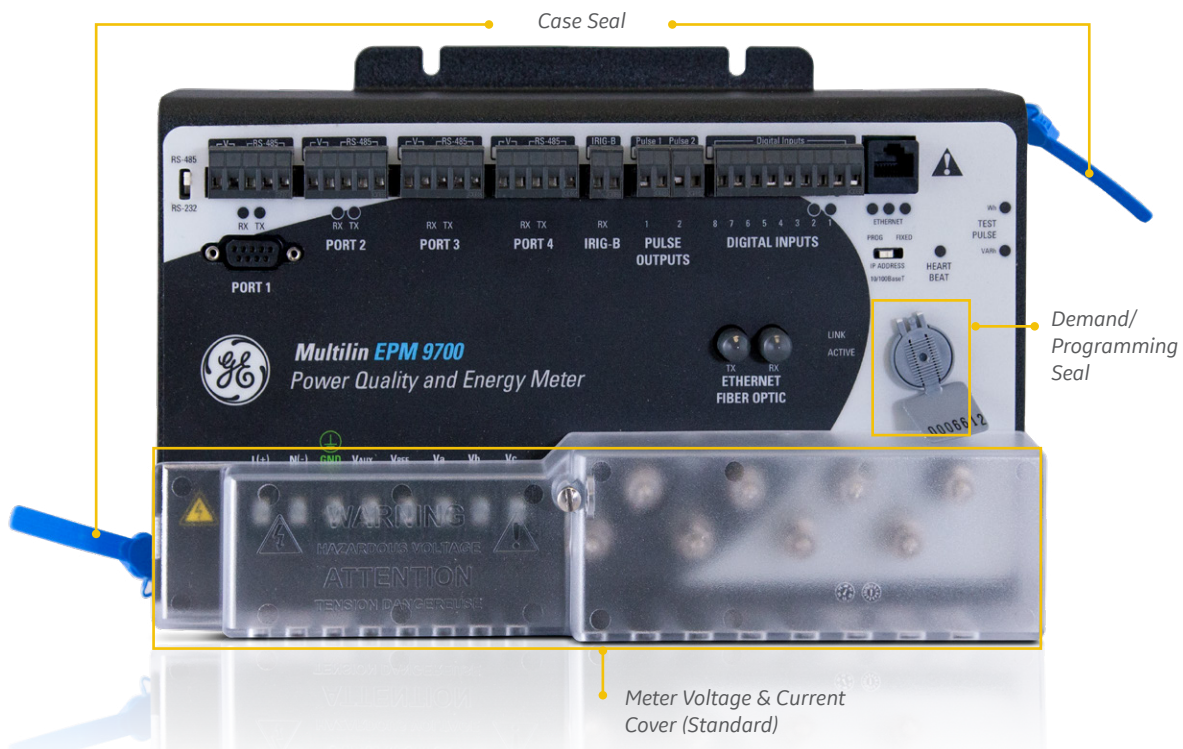

## WebView Energy Dashboard

The EPM 9700 supports direct remote energy and power quality data visualization through an enhanced HTML 5 based web server which provides response formatting, and browser based access on a multitude of devices including tablets, phones and workstations. The enhanced web server eliminates the need for additional hardware and/or software to access data on the particular meter remotely.

The visualization includes an Energy Dashboard providing users with easy to understand graphical real-time data, as well as to analyze stored historical logs, alarms, and waveform records.

Using the WebView™ Energy Dashboard, the user is able to navigate easily through multiple webpage views, to view a multitude of detailed information on energy usage and power quality such as:

- Detailed charts and graphical trending of real time energy, voltage and current readings to compare past and present values
- Energy usage including tables for demand and usage along with quadrant energy charts
- Phasor readings and a graphical phasor chart
- Waveform event records, including functionality for zoom and pan for detailed visualization and analysis
- Short term (Pst) and Long term (Plt) Flicker readings
- Detailed information for status of digital inputs, KYZ accumulators/aggregators
- Detailed log information/status
- Meter and diagnostic Information for meter applications and troubleshooting

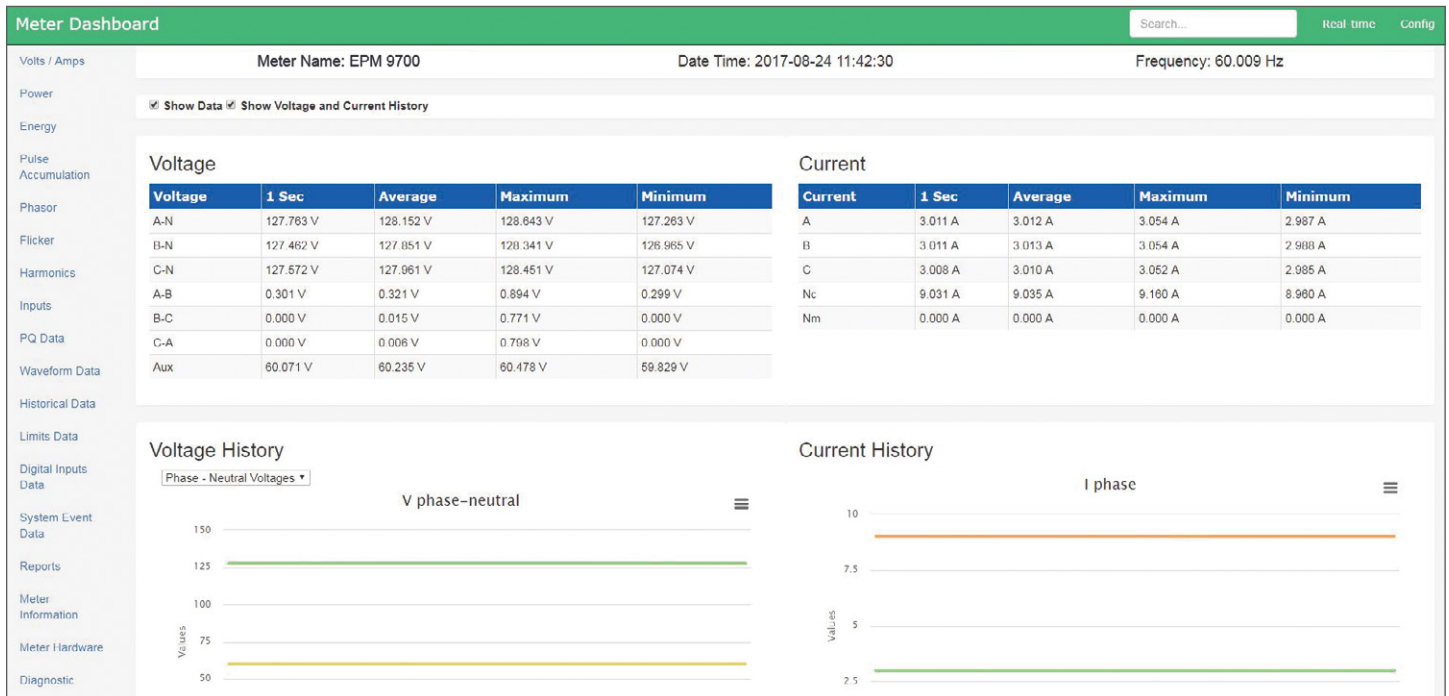

Sample of watt and VAR trending over webpage

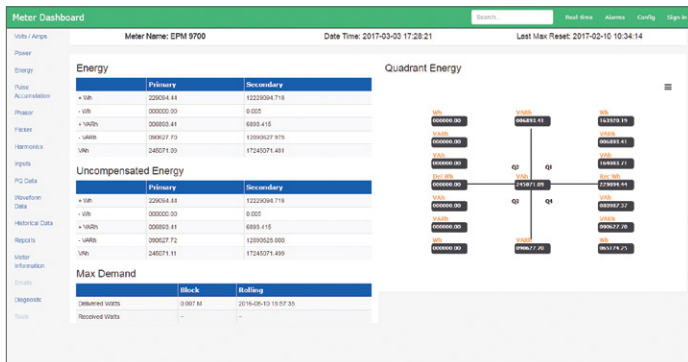

Energy screen

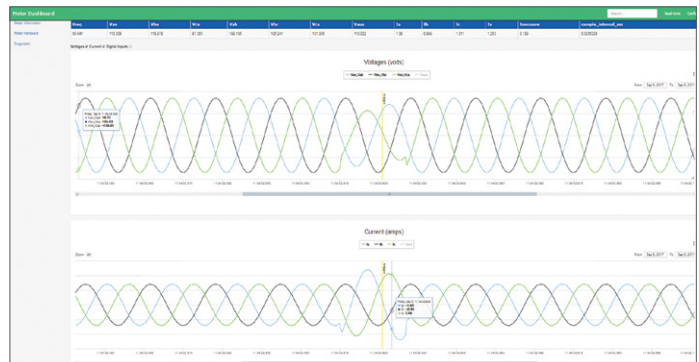

Waveform Recording Screen



### Dimensional Drawing – EPM 9700 Meter Base

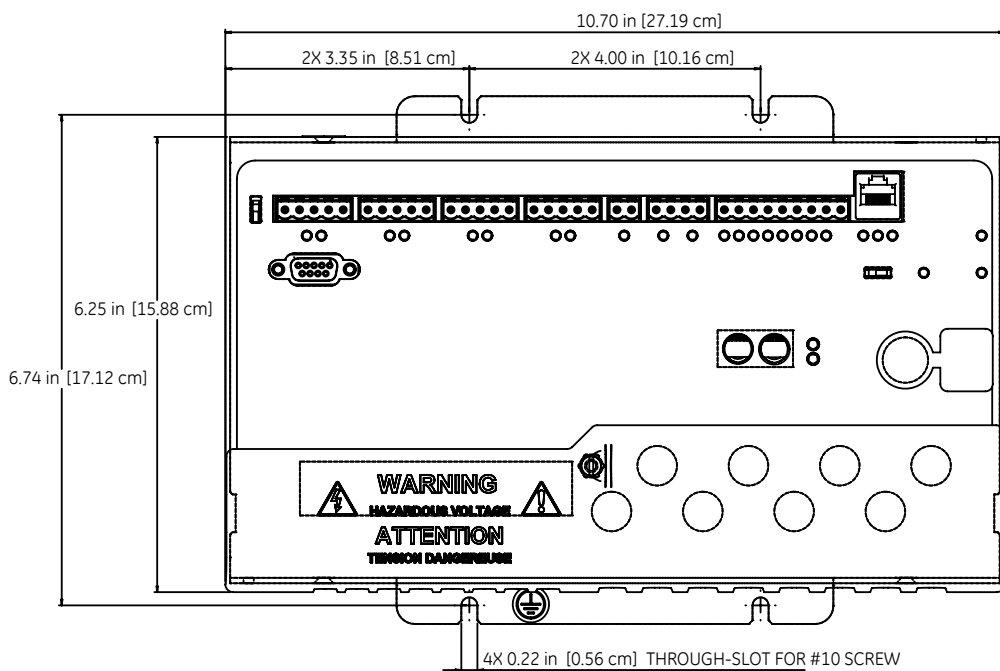

EPM 9700 Front Dimensions

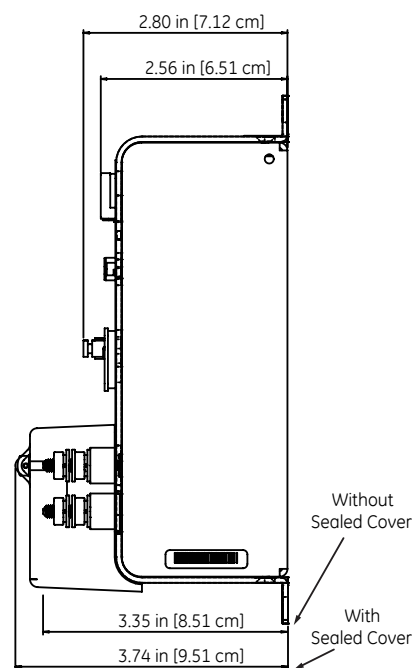

EPM 9700 Side Dimensions

### Dimensional Drawing – P40NPLUS Display

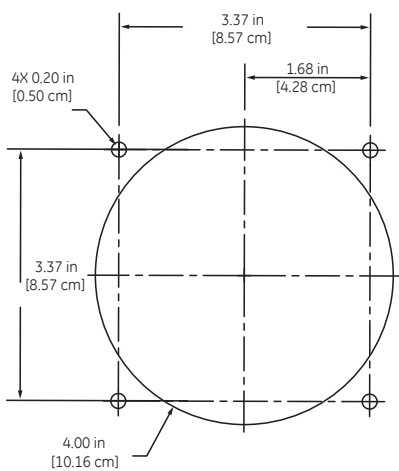

P40NPLUS Back Dimensions

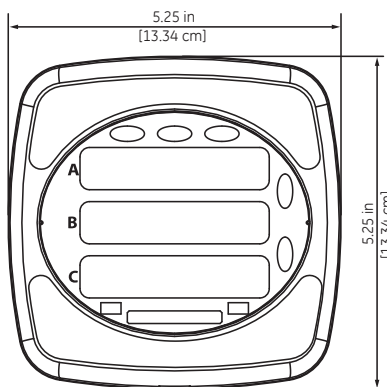

P40NPLUS Front Dimensions

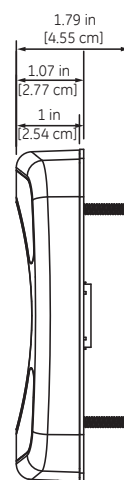

P40NPLUS Side Dimensions

Wiring Diagrams

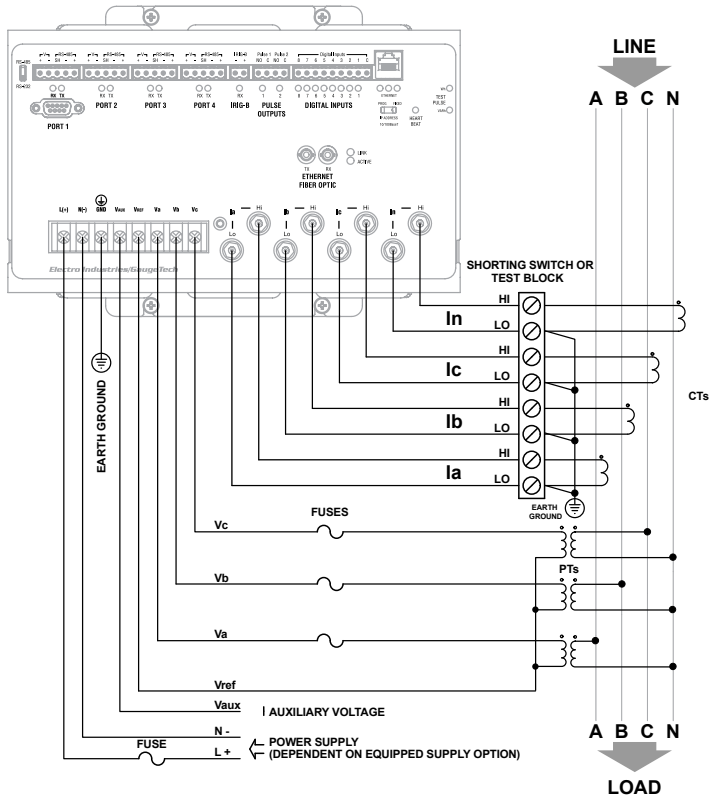

4-Wire Wye, 3-Element Direct Voltage with 4 CTs

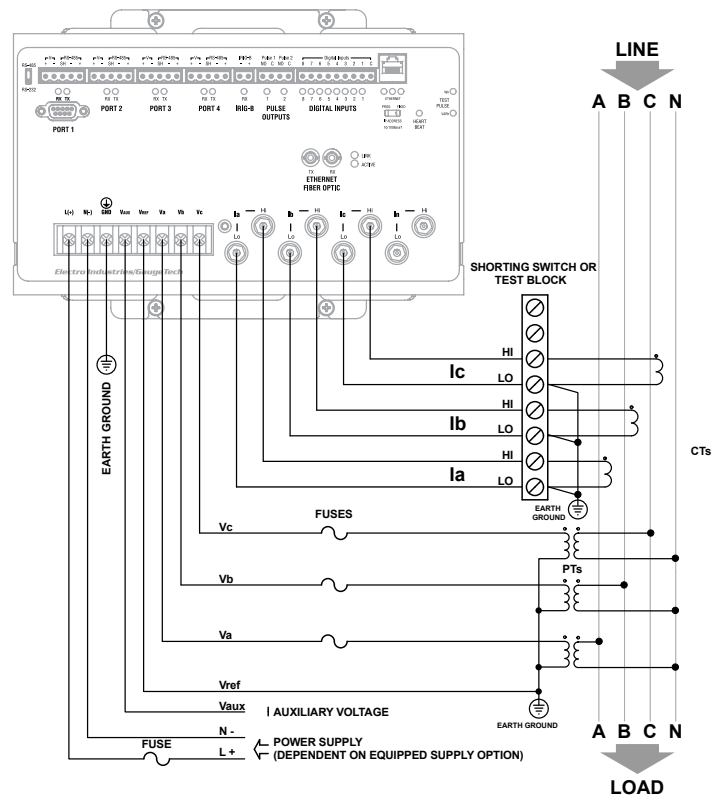

4-Wire Wye, 3-Element with 3 PTs and 3 CTs

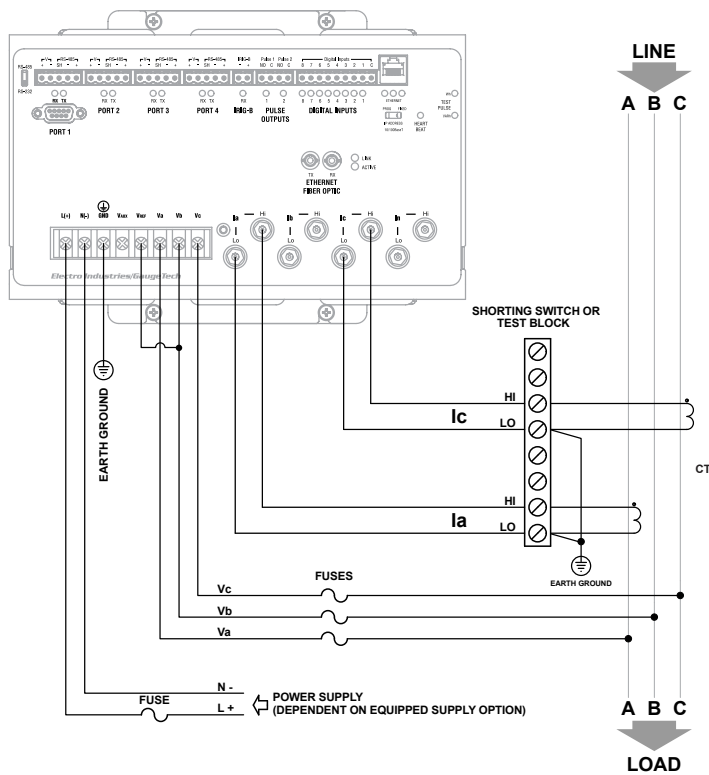

3 Wire, 2 Element Delta Direct Voltage with 2 CTs  
Important: The Potential between A, B, C and GROUND must be less than 347 V AC

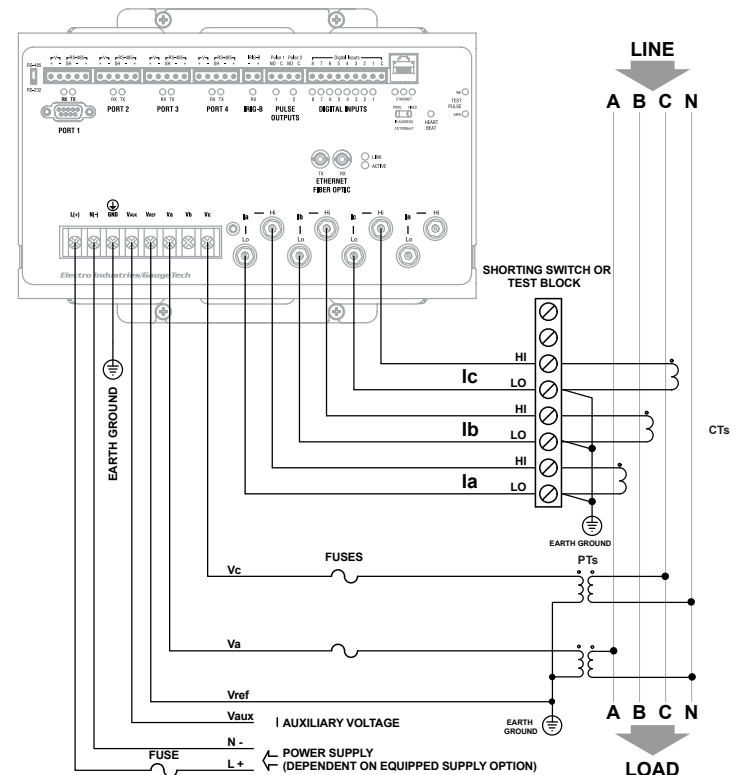

3 Phase, 4 Wire 2.5-Element with 2 PTs, 3 CTs

## Technical Specifications

### VOLTAGE INPUT RANGE:

- (20 to 720) V AC
- Pickup voltage: 5 V AC

### ISOLATION:

- Voltage Inputs isolated to 2500 V AC

### CURRENT INPUT RANGE:

- Supports Class 2 and Class 20 in one input configuration
- Programmable to any CT ratio
- Fault current recording to +/- 80 A peak
- Pick-up current: 1 mA

### CURRENT INPUT WITHSTAND CAPABILITY (AT 23 °C):

- 100 A for 10 seconds
- 300 A for 3 seconds
- 500 A for 1 second

### BURDEN

- Voltage Inputs: 5 Mohms per Voltage Input
- Current Inputs: 0.028 VA per phase max at 20 A

### FREQUENCY RANGE:

- (42.5–69.5) Hz

### ENVIRONMENTAL:

- Operating temp: (-25 to +70) °C
- Storage temp: (-40 to +70) °C
- Humidity: Up to 95% RH non-condensing
- Protection Class: IP30

### MEASUREMENT METHOD:

- Up to 1024 samples per cycle (programmable)
- 16 Bit A/D resolution – multiple simultaneous converters
- Multi-Gain™ sensing method
- True RMS

### ACCURACY RATINGS:

- Energy measurement accuracy at 0.06% (0.025 A to 20 A at PF=1)
- Full accuracy specifications available in EPM 9700 Instruction Manual
- Time clock: 3.5 ppm for (-25 to +70) °C - less than 10 seconds drift per month on crystal sync; 2.0 ppm. Typical from 0 to +40 °C - less than 6 seconds per month drift

### UPDATE RATE

- 1 Second - High Accuracy readings
- 1 Cycle - Fast Update readings
- Customizable high-speed readings - update rate from 2 to 20 cycles RMS

### CONTROL POWER REQUIREMENTS:

- Option 0: Universal (100-240) VAC @50/60 Hz or (100-240) VDC
- Option 1: 18 to 60 VDC
- Burden: 20 VA max w/o I/O or display; 40 VA max with I/O and display

### COMMUNICATION:

- Baud rate up to 115200 bps
- Programmable parity and stop bits
- Serial Communication protocols: Modbus ASCII/RTU, DNP 3.0
- Ethernet: Modbus TCP, DNP 3.0, SNMP, HTTP, and HTTPS
- RJ45 Ethernet port 10/100BaseT
- Fiber Optic port 100Base FX
- 4 RS485 ports
- RS232 port (shared)
- RS485 serial ports have 18 V DC output for I/O
- Optional P40NPLUS display offers USB Type B communication

### SHIPPING

- Total shipping weight: approx. 5 lbs (2.2 kgs)
- Shipping container dimensions: 14" x10" x6" (35.6cm x 25.4cm x 15.2cm)
- Displays and I/O modules ship in separate containers

### COMPLIANCE:

- UL/cUL Listed E200431
- CE Marked
- EU Directive 2014/32/EU (Measuring Instruments Directive)
- EU Directive 2011/65/EU (RoHS 2 Directive)
- REACH Regulation (EC) No 1907/2006
- ANSI C12.1 Electric Meters Code for Electricity Metering
- ANSI C12.20 Electricity Meters 0.2 and Electricity Metering
- ANSI C12.20 Electricity Meters 0.2 and 0.5 Accuracy Classes
- ANSI (IEEE) C37.90.1 (Surge Withstand)
- ANSI C62.41 (Burst)
- IEC 60068-2-1 Environmental Testing: Test A: Cold
- IEC 60068-2-2 Environmental Testing: Test B: Dry Heat
- IEC 60068-2-30 Environmental Testing: Test Db: Damp heat, cycle (12h + 12h cycle)
- IEC 61000-4-2 Electromagnetic compatibility (EMC). Testing and measurement techniques. Electrostatic discharge immunity test
- IEC 61000-4-3 Electromagnetic compatibility (EMC). Radiated, radiofrequency, electromagnetic field immunity test
- IEC 61000-4-4 Electrical fast transient/burst immunity test
- IEC 61000-4-5 Surge immunity test
- IEC 61000-4-6 Immunity to conducted disturbances, induced by radiofrequency fields
- IEC 61000-4-7 General guide on harmonics and interharmonic measurements and instrumentation
- IEC 61000-4-30 Power quality measurement methods
- IEC 62052-11 General requirements, tests and test conditions - Metering equipment IEC 62053-22 Particular Requirements - Static meters for active energy (Classes 0,2 S and 0,5 S)
- IEC 62053-23, Static meters for reactive energy (Classes 2 and 3)
- IEEE 519 Recommended Practices and Requirements for Harmonic Control in Electrical Power Systems

## Ordering Codes

### EPM 9700 Meter

	X	*	*	*	X	X	X	Description
<b>Base Unit</b>	PL9700	X						EPM 9700 Multi-function metering system Reserved for future use
<b>Frequency</b>		X						60 Hz AC frequency system 50 Hz AC frequency system
<b>Control Power</b>			0					Universal (100-240) VAC @50/60 Hz or (100-240) VDC 18 to 60 VDC
<b>Software</b>			1	A	X	X	X	Standard: 512MB Memory, 512 Samples/Cycle Advanced: 1.2GB Memory, 1024 Samples/Cycle Reserved for future use
				B	X	X	X	

### EPM 9700 Display and Accessories

	GE PART NUMBER	DESCRIPTION
<b>Display</b>	PL9000P40NPLUS0	P40NPLUS Three line LED Display with 6ft cable
<b>Display cables</b>	PL9000ACC420	P40NPLUS Display Cable only - 20 ft. length
<b>External Input/Output (I/O) Modules</b>	<b>ANALOG OUTPUT MODULES</b>	
	PL90001MAON4000	4 Channel 0-1 mA Analog Outputs
	PL90001MAON8000	8 Channel 0-1 mA Analog Outputs
	PL90002OMAON400	4 Channel 4-20 mA Analog Outputs
	PL90002OMAON800	8 Channel 4-20 mA Analog Outputs
	<b>ANALOG INPUT MODULES</b>	
	PL90008AI100000	8 Channel 0-1mA Analog Inputs
	PL90008AI200000	8 Channel 4-20mA Analog Inputs
	PL90008AI300000	8 Channel 0-5V DC Analog Inputs
	PL90008AI400000	8 Channel 0-10V DC Analog Inputs
<b>Digital Dry Contact Relay/Solid State Pulse Outputs</b>	PL90004RO100000	4 Relay Outputs, 5A, 250VAC/30 VDC, Form C Latching
	PL90004PO100000	4 Solid State Pulse Outputs, Form A or C KYZ Pulses, 20 Pulses/sec. Max.
<b>Digital Status Inputs</b>	PL90008DI100000	8 Channel Auxiliary Digital Status Inputs
<b>I/O Power Supply</b>	PL9000PSIO00000	Auxiliary Power Supply (Required for External I/O Modules)
<b>I/O Mounting Bracket</b>	PL9000MBIO00000	Mounting Bracket (Required for External I/O Modules)
<b>EPM 9700 DIN Rail Mount Kit</b>	PL9000ACCDIN	EPM 9700 DIN Rail Mount Kit
<b>Software License</b>	PLSOFTCOMS	GE Communicator - EPM Meter Setup Software License

## GEGridSolutions.com

IEC is a registered trademark of Commission Electrotechnique Internationale. IEEE is a registered trademark of the Institute of Electrical Electronics Engineers, Inc. Modbus is a registered trademark of Schneider Automation. NERC is a registered trademark of North American Electric Reliability Council. NIST is a registered trademark of the National Institute of Standards and Technology.

GE, the GE monogram, Multilin, EPM, EnerVista and CyberSentry are trademarks of General Electric Company.

GE reserves the right to make changes to specifications of products described at any time without notice and without obligation to notify any person of such changes.

Copyright 2018, General Electric Company. All Rights Reserved.

GEA-32053-(EN)  
English  
180904



imagination at work