



INSTRUCTIONS

GEK-28008D

AUXILIARY RELAYS

HMA11A-B-C-D-E-F

GENERAL  ELECTRIC

CONTENTS

	<u>PAGE</u>
DESCRIPTION.....	3
RATINGS.....	3
BURDENS.....	3
CHARACTERISTICS.....	4
ELECTRICAL TESTS.....	4
PICK UP TEST.....	4
MECHANICAL ADJUSTMENTS.....	5
CONSTRUCTION.....	5
RECEIVING, HANDLING AND STORAGE.....	5
PERIODIC CHECKS AND ROUTINE MAINTENANCE.....	5
CONTACT CLEANING.....	5
RENEWAL PARTS.....	6

DESCRIPTION

The Type HMA11 relay is an instantaneous auxiliary device whose contacts are operated by the movement of a hinged armature. Models are available for operation on all standard AC and DC voltages. The Type HMA11 relay is available as a back connected relay supplied either with or without cover or as a front connected relay without cover. The contact arrangements available are either a double pole, double throw or one normally open and one normally closed contact with overlap. The various Type HMA11 relay models are summarized in the following table:

RELAY	CONTACT ARRANGEMENT	CONNECTION
HMA11A	DPDT	BACK CONNECTED
HMA11B	DPDT	FRONT CONNECTED
HMA11C	1 N.O. & 1 N.C.	BACK CONNECTED
HMA11D	1 N.O. & 1 N.C.	FRONT CONNECTED
HMA11E**	DPDT	FRONT CONNECTED
HMA11F***	DPDT	FRONT CONNECTED

** HMA11E is supplied with loose connecting hardware.
 *** HMA11F is supplied with a high temperature coil.

RATINGS

The HMA11 relays are available with coil ratings for standard voltage up to 460 volts for 25, 50, or 60 cycles and up to 250 volts DC.

The current closing ratings of the contacts is 30 amperes. The current carrying rating is 12 amperes continuously or 30 amperes for one minute. The interrupting ratings (non-inductive circuits) for the various voltages are listed in the following table:

	D-C				A-C		
VOLTS	24	48	125	250	115	230	460
AMPS	12	6	1.5	0.5	25	15	5

BURDENS

D-C COILS			
VOLTS	FREQ.	D-C RES.	WATTS IN COIL
6	d-c	15.3	2.4
12	d-c	65	2.2
24	d-c	250	2.3
48	d-c	960	2.4
62.5	d-c	1450	2.7
125	d-c	5660	2.8
250	d-c	**930	3.2

** Uses an external resistor of 3300 ohms in series with the coil.

These instructions do not purport to cover all details or variations in equipment nor to provide for every possible contingency to be met in connection with installation, operation or maintenance. Should further information be desired or should particular problems arise which are not covered sufficiently for the purchaser's purposes, the matter should be referred to the General Electric Company.

To the extent required the products described herein meet applicable ANSI, IEEE and NEMA standards; but no such assurance is given with respect to local codes and ordinances because they vary greatly.

Certain quantities should be defined before giving BURDEN DATA for A-C coils.

R_{D.C.} is the resistance of a coil as measured with an ohmmeter, bridge, etc.

R_{D.O.} is the A-C resistance of a coil when A-C power is flowing through the coil but the relay is not picked up. X_{D.O.} is the inductive impedance when the coil is energized but the relay is not picked up. R_{p.U.} and X_{p.U.}; the resistive and inductive parts of impedance of coil under picked up conditions are designated as R_{p.U.} and X_{p.U.}.

Z_{D.O.} is the impedance of the relay in drop out conditions. Z_{p.U.} is the impedance of the relay in picked up conditions.

A.C. COILS								
COILS	RATINGS	R _{D.C.}	R _{D.O.}	X _{D.O.}	Z _{D.O.}	R _{p.U.}	X _{p.U.}	Z _{p.U.}
VOLTS	CYCLE	± 10%	± 10%	± 10%	± 10%	± 5%	± 5%	± 5%
115	60	330	440	864	975	1215	1342	1815
230	60	1300	2580	3310	4180	5160	4500	6900
460	60	5100	7040	13825	15600	19440	21475	29040
115	50	380	503	871	1006	1323	1552	2029
230	50	1500	2010	3480	4025	5300	6200	8120
460	50	6080	8050	13940	16100	21200	24840	32500
115	25	1300	1820	1180	2156	3266	1933	3833
230	25	5100	7200	4700	8600	13050	7710	15160
460	25	20800	29100	18880	34500	52250	31000	61330

CHARACTERISTICS

The HMA11 relay is a hinged armature type, instantaneous auxiliary device. When the coil is energized, a magnetic flux flows through the frame pole piece and attracts the armature. Two auxiliary contacts are mechanically coupled to the armature. The auxiliary contacts are normally two form "C" contacts (see internal connections diagram). These contacts can be used to make or break auxiliary circuits.

ELECTRICAL TESTS

PICK UP TEST

Pick-up is defined as the minimum voltage or current at which the armature operates and seals firmly against the pole piece. The two movable contacts are electrically separate and are held in position on the armature by means of an insulated contact carrier and spring housing. The control spring tension (see Fig. 1) can be adjusted by bending the anchor arm. The spring should be adjusted so that the highest value of pickup is obtained without exceeding 80% of Rated AC volts or 60% of rated DC volts.

The pick up and DO voltages for DC relays, after being continuously energized at rated voltage, increases by 10% to 20%. Similarly, in the case of AC relays, the pickup and dropout voltage increases by 3% to 8%.

All alternating current operated devices are affected by frequency. Since non-sinusoidal waveforms can be analyzed as a fundamental frequency plus harmonics of the fundamental frequency, it follows that alternating current devices (relays) will be affected by the applied waveform.

Therefore, in order to properly test alternating current relays it is essential to use a sine wave of current and/or voltage. The purity of the sine wave (i.e. its freedom from harmonics) cannot be expressed as a finite number for any particular relay, however, any relay using tuned circuits, R-L or RC networks, or saturating electromagnets (such as time overcurrent relays) would be especially affected by non-sinusoidal waveforms.

Similarly, relays requiring dc control power should be tested using dc and not full wave rectified power. Unless the rectified supply is well filtered, many relays will not operate properly due to the dips in the rectified power. Zener diodes, for example, can turn off during these dips. As a general rule the dc source should not contain more than 5% ripple.

MECHANICAL ADJUSTMENTS

There should be at least 1/16" wiper on the normally closed "b" contacts and the normally open "a" contacts as measured at the top of the moving contact carrier. To determine, operate the armature by hand and check that there is at least 1/16" movement of the top edge of the contact carrier after the contacts have made.

When the armature is operated by hand, the "a" contact should make within 1/32" of each other i.e., with one contact just making, the gap of the other should never be more than 1/32". This also applies to the "b" contacts.

For all back connected relays with cover, check that there is at least 1/32" clearance between the armature tailpiece and the bottom inside surface of the cover. There is a special cover with cutouts in the sides available to check this clearance.

CONSTRUCTION

The HMA11 relay consists of a molded case. The various parts of the relay can be seen in Figure 1. The control spring helps in adjusting the pickup and dropout voltage. The function of voltage barrier is to avoid a flash over between a pair of electrically separate but mechanically coupled normally closed contacts or between a pair of normally open contacts. Cover spring clips maintain the spring force against the cover and prevent them from getting off its desired position.

RECEIVING, HANDLING AND STORAGE

These relays, when not included as a part of a control panel will be shipped in cartons designed to protect them against damage. Immediately upon receipt of a relay, examine it for any damage sustained in transit. If injury or damage resulting from rough handling is evident, file a damage claim at once with the transportation company and promptly notify the nearest General Electric Apparatus Sales Office.

Reasonable care should be exercised in unpacking the relay in order that none of the parts are injured or the adjustments disturbed.

If the relays are not to be installed immediately, they should be stored in their original cartons in a place that is free from moisture, dust and metallic chips. Foreign matter collected on the outside of the case may find its way inside when the cover is removed and cause trouble in the operation of the relay.

PERIODIC CHECKS AND ROUTINE MAINTENANCE

In view of the vital role of protective relays in the operation of a power system it is important that a periodic test program be followed. It is recognized that the interval between periodic checks will vary depending upon environment, type of relay and the user's experience with periodic testing. Until the user has accumulated enough experience to select the test interval best suited to his individual requirements, it is suggested that the points listed under INSTALLATION PROCEDURE be checked at an interval of from one to two years.

CONTACT CLEANING

For cleaning relay contacts, a flexible burnishing tool should be used. This consists of a flexible strip of metal with an etched-roughened surface resembling in effect a superfine file. The polishing action is so delicate that no scratches are left, yet it will clean off any corrosion thoroughly and rapidly. Its flexibility insures the cleaning of the actual points of contact. Do not use knives, files, abrasive paper or cloth of any kind to clean relay contacts.

RENEWAL PARTS

It is recommended that sufficient quantities of renewal parts be carried in stock to enable the prompt replacement of any that are worn, broken, or damaged.

When ordering renewal parts, address the nearest Sales Office of the General Electric Company, specify quantity required, name of the part wanted, and the complete model number of the relay for which the part is required.

Since the last edition, a change has been made in the Periodic Tests section, and Figure 3 has been changed.

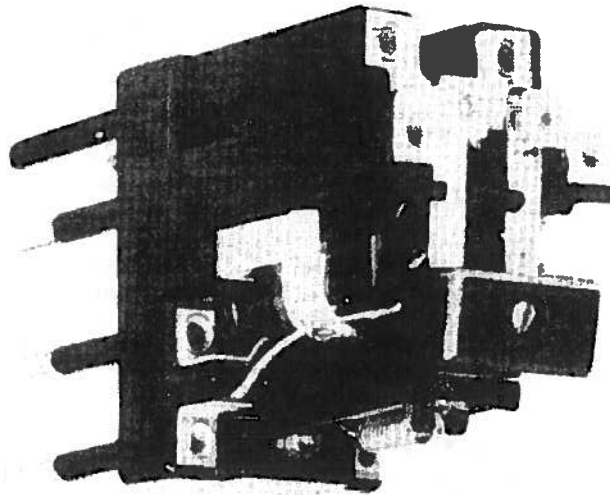
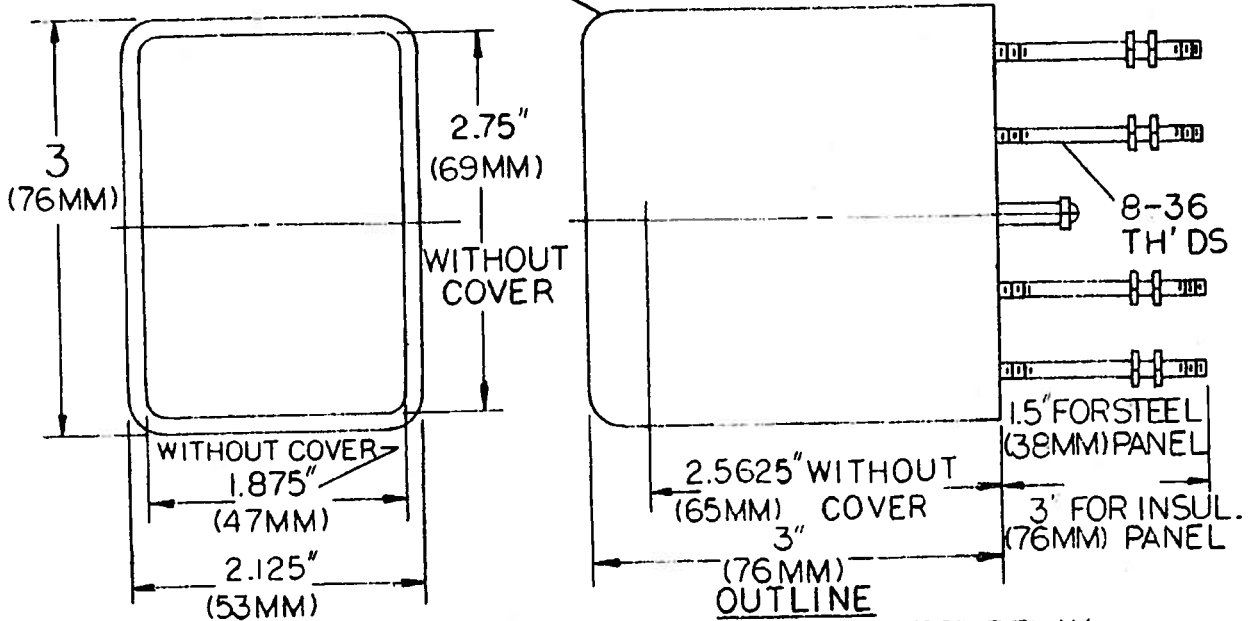
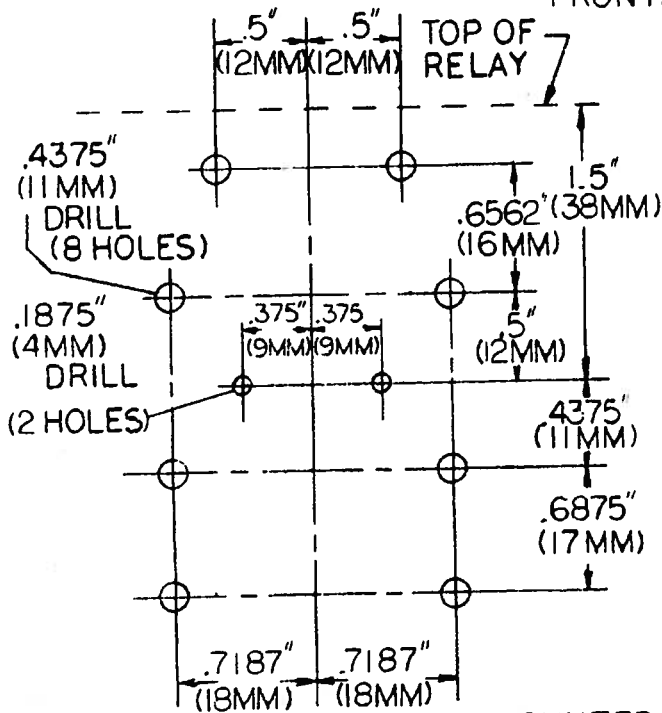

FIG. 1 (8042328-) HMA RELAY WITHOUT THE COVER

OMIT STUDS & COVER & ASM MTG. SCREW FROM THE FRONT ON FRONT CONNECTED RELAY



FRONT & BACK CONNECTED RELAY



BACK CONNECTED BACK MOUNTED HMA11 PANEL DRILLING FRONT VIEW

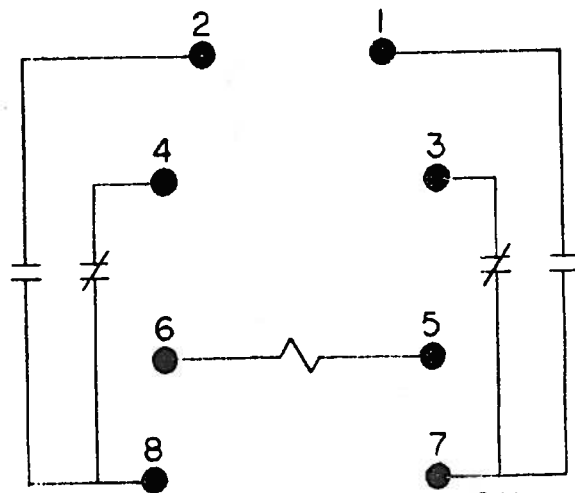

INTERNAL CONNECTION (FRONT VIEW)

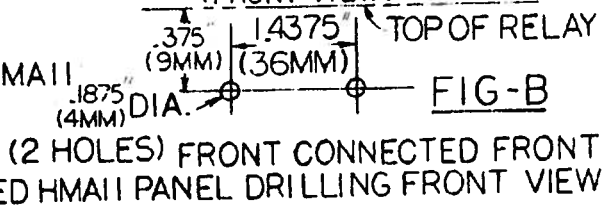

FRONT CONNECTED FRONT MOUNTED HMA11 PANEL DRILLING FRONT VIEW

FIG. 2 (K-6400789 [8]) OUTLINE, PANEL DRILLING DIMENSIONS AND INTERNAL CONNECTIONS FOR TYPE HMA11A, HMA11B, HMA11E AND HMA11F RELAYS

OMIT STUDS & COVER; & ASM. MTG. SCREW FROM THE FRONT ON THE FRONT CONNECTED RELAY

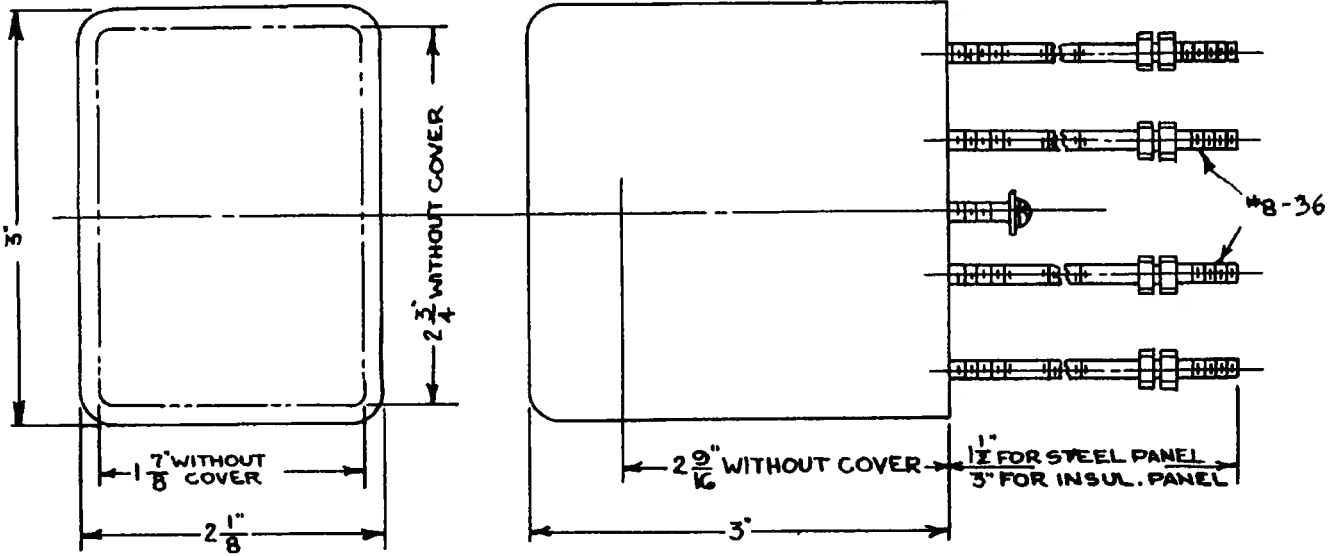

OUTLINE
(FRONT & BACK CONNECTED RELAY)

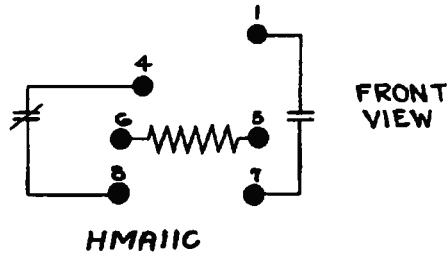
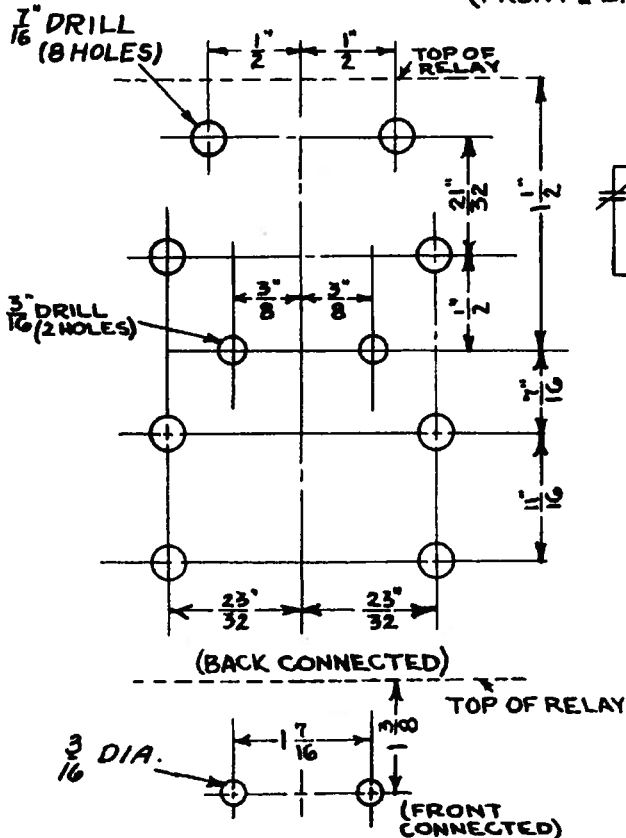

INTERNAL CONNECTIONS
(FRONT VIEW)

FIG 3 (K-6400440 [5]) OUTLINE, PANEL DRILLING DIMENSIONS AND INTERNAL CONNECTIONS FOR TYPE HMA11C AND HMA11D RELAY